

HOME VENTILATION WITH HEAT RECOVERY

## M-WRG-S... ventilation units

Surface-mount installation

Surface-mount installation with ductwork connection

Flush-mount installation

Flush-mount installation with ductwork connection

U<sup>2</sup> integrated into wall installation with ductwork connection



# INSTALLATION MANUAL

Part no. 5253-01 Week 45/2022 EN

# Contents

<b>1</b>	<b>Introduction</b>	<b>5</b>
1.1	Notes on this installation manual	5
1.2	Description	5
1.3	Target group	6
1.4	EU declaration of conformity	6
1.5	National technical approval (for Germany)	7
1.6	Nameplate	7
1.7	Storage	7
1.8	Environmentally-friendly disposal	7
1.9	Revision index	7
1.10	Explanation of the symbols used	7
1.11	Supplementary documents	8
<b>2</b>	<b>Safety instructions</b>	<b>9</b>
2.1	Hazard classification	9
2.2	Notes on using the ventilation units safely	9
2.2.1	Fire protection	9
2.2.2	Operation with fireplaces	9
2.2.3	Installation in wet areas	10
2.2.4	Build-up of icicles and ice patches at low temperatures	10
2.2.5	Starting and using the ventilation unit	10
2.3	Notes on using the ventilation units	10
2.4	Note on use in conjunction with room air conditioners	11
2.5	Intended use	11
<b>3</b>	<b>Planning notes</b>	<b>12</b>
3.1	Surface-mount installation	12
3.1.1	Requirements for the installation wall	12
3.1.2	Positioning the ventilation unit indoors	12
3.1.3	Unrestricted access to the ventilation unit	13
3.1.4	Electrical connection	14
3.2	Flush-mount installation	14
3.3	U <sup>2</sup> integrated into wall installation	14
<b>4</b>	<b>Warranty and liability</b>	<b>15</b>
4.1	Warranty	15
4.2	Liability	15
<b>5</b>	<b>Dimensions</b>	<b>16</b>
5.1	Ventilation unit without duct adapters	16
5.2	Ventilation unit with duct adapters for surface-mount and U <sup>2</sup> integrated into wall installation	17
5.3	Ventilation unit with duct adapters for flush-mount installation	17

<b>6</b>	<b>Items supplied</b> .....	<b>18</b>
6.1	M-WRG-S... ventilation unit .....	18
6.2	Installation materials required .....	19
6.2.1	Surface-mount installation .....	19
6.2.2	Flush-mount installation with ductwork connection .....	19
6.2.3	U <sup>2</sup> integrated into wall installation .....	19
<b>7</b>	<b>Overview of the modules</b> .....	<b>20</b>
7.1	Ventilation unit – with unit cover attached .....	20
7.2	Ventilation unit – with unit cover removed .....	20
7.3	Outer wall terminal .....	20
<b>8</b>	<b>Tools and equipment required</b> .....	<b>21</b>
8.1	Surface-mount installation .....	21
8.2	Flush-mount installation .....	21
8.3	U <sup>2</sup> integrated into wall installation .....	21
<b>9</b>	<b>General installation instructions</b> .....	<b>21</b>
9.1	Surface-mount installation / flush-mount installation / U <sup>2</sup> integrated into wall installation .....	22
9.2	Electrically disconnecting mains cables .....	22
<b>10</b>	<b>Surface-mount installation</b> .....	<b>23</b>
10.1	Marking positions of core drill holes with drilling template .....	23
10.2	Drilling core drill holes .....	24
10.3	Drilling holes for dowels and making marks for connecting cables .....	24
10.4	Condensate drain on the exhaust air pipe .....	25
10.5	Chasing out channels for connecting cables .....	26
10.6	Inserting the ventilation pipes .....	26
10.7	Drilling the holes for the outer wall terminal .....	27
10.8	Fixing ventilation pipes and filling gaps with foam .....	27
10.9	Running the connecting cables .....	28
10.9.1	Cable types .....	29
10.9.2	External control input .....	30
10.10	Plastering the internal wall .....	31
10.11	Cutting ventilation pipes on internal wall to length .....	31
10.12	Sealing ventilation pipes on external wall .....	32
10.13	Attaching the outer wall terminal .....	32
<b>11</b>	<b>Installing the ventilation unit</b> .....	<b>33</b>
11.1	Removing the unit cover from the ventilation unit .....	33
11.2	Checking the seals around the air spigots .....	33
11.3	Inserting fixing screws with centring guides into the ventilation unit .....	34
11.4	Removing the supply air hood .....	34
11.5	Removing the network connection cover (on certain ventilation unit types only) .....	35

11.6	Threading in cables through the opening .....	35
11.7	Fixing the ventilation unit .....	36
11.7.1	Surface-mount installation .....	36
11.7.2	Flush-mount installation .....	36
11.7.3	U <sup>2</sup> integrated into wall installation .....	37
11.8	Connecting the mains cable and control cable (if used) .....	39
11.9	Fixing the supply air hood .....	40
11.10	Inserting the network connection cover (on certain ventilation unit types only) .....	40
11.11	Attaching the unit cover to the ventilation unit .....	41
11.12	Attaching the blind frame (optional for flush-mount installation without ductwork connection) .....	41
11.13	Attaching the U <sup>2</sup> cover plate (for U <sup>2</sup> integrated into wall installation only) .....	42
11.14	Connecting flat ducts to the ventilation unit (for surface-mount installation with ductwork connection only) .....	42
11.15	Fixing the duct adapter (for flush-mount installation with ductwork connection only) ...	43
11.16	Starting up the ventilation unit .....	43

# 1 Introduction

## 1.1 Notes on this installation manual



This installation manual contains important information that should be followed when installing the M-WRG-S... ventilation units.

- ▶ Read all the instructions carefully before installing the ventilation unit to avoid possible risks and mistakes.
- ▶ When assembly is complete, give these instructions to the home owner, caretaker or property manager.
- ▶ These instructions are part of the product. Keep the instructions in a safe place for future reference.

### **⚠ WARNING**

- ▶ Follow ALL danger and warning instructions and notes on precautionary measures.
- ▶ Read section “2 Safety instructions” on page 9 carefully.

## 1.2 Description

This manual describes the installation of the following variants of M-WRG-S... decentralised ventilation units:

- Surface-mount installation (see Fig. 1)
- Surface-mount installation with ductwork connection (see Fig. 2)
- Flush-mount installation (see Fig. 3 on page 6)
- Flush-mount installation with ductwork connection (see Fig. 4 on page 6)
- U<sup>2</sup> integrated into wall installation with ductwork connection (see Fig. 5 on page 6)



Fig. 1: Surface-mount installation



Fig. 2: Surface-mount installation with ductwork connection



Fig. 3: Flush-mount installation



Fig. 4: Flush-mount installation with ductwork connection

### 1.3 Target group

The activities described in this manual must only be carried out by specialised personnel with the following qualifications:

- Training in the installation and commissioning of electrical devices
- Training in electrical hazards and the local safety requirements
- Knowledge of the relevant standards and directives
- Knowledge and observance of this document and all the safety instructions

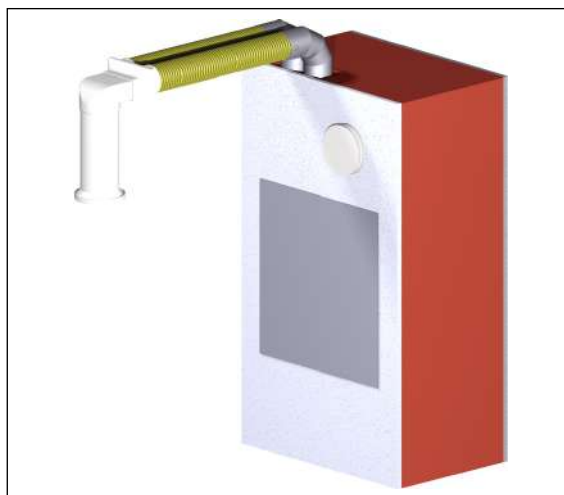

Fig. 5: U<sup>2</sup> integrated into wall installation with ductwork connection

### 1.4 EU declaration of conformity

The M-WRG-S... ventilation units manufactured by  
Meltem Wärmerückgewinnung GmbH & Co. KG  
Am Hartholz 4  
82239 Alling

conform to the regulations and standards listed in the EU Declaration of Conformity provided.

## 1.5 National technical approval (for Germany)

A valid national technical approval from the Deutsches Institut für Bautechnik (DIBt) must be obtained for the ventilation unit before it is installed in Germany. This approval can be provided upon request or can be downloaded from our website at [www.meltem.com/service/downloads/](http://www.meltem.com/service/downloads/) (see also the QR code on the back page of these instructions).

The approval number is Z-51.3-138 (see item 1 in Fig. 7).

- For installation outside Germany, the national regulations applicable in your country should be followed.

## 1.6 Nameplate

 Wärmerückgewinnung GmbH & Co. KG Am Hartholz 4 82239 Alling www.meltem.com Tel.: 08141-40 41 79-0			
Device no.:	Type: M-WRG-S		
	Part no.: 5010		
	max. 37 W		
	230 V	50 Hz	IPX1
	CE		iso-Kl. B

Fig. 6: Nameplate

You will find the nameplate on the intermediate plate on the inside of the housing (see item 2 in Fig. 7).



Fig. 7: Position of approval number and nameplate

## 1.7 Storage

- Store the ventilation unit in its original packaging in a dry place where the temperature ranges between 0 °C and +40 °C.

## 1.8 Environmentally-friendly disposal

The ventilation units must not be disposed of in the residual waste bin.

- Dispose of the ventilation unit in accordance with the waste disposal regulations that apply on site.

## 1.9 Revision index

Edition	Manual	Date
1 <sup>st</sup> edition	Installation manual for M-WRG-S... ventilation units	Week 45/2022 EN

## 1.10 Explanation of the symbols used

- This symbol indicates an action to be taken.
- This symbol indicates a list.

## 1.11 Supplementary documents

<b>Manual</b>	<b>Part no.</b>
Installation manual for flush-mount installation kit with plastering trim (solid construction) M-WRG-M/MB	5250-01
Installation manual for flush-mount installation kit M-WRG-M (frame construction)	5251-01
Installation manual for flush-mount installation kit M-WRG-M/MB-U <sup>2</sup>	5252-01
Installation manual for outer wall terminals M-WRG-II ES..., M-WRG-ES..., M-WRG-II KSR...	744005EN
Installation manual for duct adapter M-WRG-KA/UP	5300-30-01
Installation manual for window reveal installation kit	5300-60-01
Operating instructions for M-WRG-S ventilation unit	5302-00-01

Table 1: Supplementary documents



## 2 Safety instructions

This manual contains notes that you must follow for your own personal safety and to avoid injury and damage to property. They are highlighted by warning triangles and are shown as follows according to the level of danger.

### 2.1 Hazard classification

#### **DANGER**

The signal word designates a hazard with a **high** degree of risk which, if it is not avoided, will result in death or severe injury.

#### **WARNING**

The signal word designates a hazard with a **medium** degree of risk which, if it is not avoided, will result in death or severe injury.

#### **CAUTION**

The signal word designates a hazard with a **low** degree of risk which, if it is not avoided, could result in minor or moderate injury.

#### **NOTICE**

A note as used in this manual contains important information about the product or about a part of the manual to which particular attention should be paid.

### 2.2 Notes on using the ventilation units safely

#### 2.2.1 Fire protection

Follow the generally applicable fire safety requirements when planning and installing the unit.

#### 2.2.2 Operation with fireplaces

- When M-WRG ventilation units are used in conjunction with fireplaces, an additional safety device (underpressure or differential pressure monitor) is needed to monitor operation and to switch off the (230 V) power supply to the units when necessary.
- Follow the requirements of the German Fire Code (FeuVo) when planning and installing the unit.
- Contact the local chimney sweep before the end of the planning phase.
- Have the chimney sweep approve the operation of the ventilation unit.
- Correct use of a ventilation system set up with the decentralised ventilation unit requires the possibility of shutting off combustion air pipes and flue systems for solid fuel fireplaces during periods in which the fireplaces are not in use.

### 2.2.3 Installation in wet areas

The following rules from DIN VDE 0100-701/702 (IEC 60364-7-701) apply to installation of M-WRG ventilation units in wet areas:

- Protection zone 0: The unit must NOT be installed in this area.
- Protection zone 1: The unit must only be installed with the “integrated into wall” U<sup>2</sup> variant. The extract and supply air valves must be installed in the top part of the wall or in the ceiling.
- Protection zone 2: The unit may be installed in this area if the mains switch is covered with a protective cap. The protective cap must be installed at the factory.
  - ▶ You will need to include the mains switch protective cap (M-WRG-SN, part no. 5430) when you order the ventilation unit.
- Other zone: The unit may be installed in this area.

Country-specific standards/regulations on observing the protection zones for installation in rooms with bathtub or shower must also be followed.

### 2.2.4 Build-up of icicles and ice patches at low temperatures

The heat recovery process in our ventilation units causes condensation. This condensation is dissipated to the outside via the exhaust air pipe. When external temperatures drop below 0 °C this can cause a build-up of icicles at the outer wall terminals and ice patches on the ground.

For this reason, the position of the units and arrangement of the outer wall terminals should be selected to eliminate any risk to people and property.

If such risks cannot be excluded, a condensate connection should be provided (see section 10.4 on page 25).

### 2.2.5 Starting and using the ventilation unit

- Do not start up the ventilation unit until it is fully installed.
- Always operate the ventilation unit with the air filters fitted.
- Always make sure that the cover is closed and locked in place before using the ventilation unit.
- Please note that the ventilation unit must not be used without the outer wall terminal for safety reasons.

### 2.3 Notes on using the ventilation units

- This unit may be used by children from 8 years old and by persons of restricted physical, sensory or mental abilities or persons lacking experience and knowledge if they are supervised or have been instructed in how to use the unit safely and understand the associated hazards. Do not allow children to play with the unit. Cleaning and user maintenance must not be carried out by children unless they are supervised.
  - ▶ Follow the regulations applicable in your country concerning the age from which people may be permitted to operate the ventilation unit.

- The ventilation unit must always be freely accessible for operation and maintenance.
  - ▶ Make sure that the ventilation unit is not covered or obstructed when the room is subsequently decorated and furnished, otherwise it cannot be operated and it will not be possible to replace the air filters. You should therefore maintain a clearance of at least 15 cm in front of the ventilation unit cover.
  - ▶ Make sure that the supply and extract air openings are not covered when the room is subsequently decorated and furnished, otherwise the ventilation unit's functions may be impaired.

## 2.4 Note on use in conjunction with room air conditioners

Condensation may form in the ventilation unit if the outdoor air temperature and humidity are high, but the room temperature is cool.

For the M-WRG ventilation units, the room temperature should therefore be set to no more than 8 °C below the external temperature.

M-WRG ventilation units and room air conditioners can be combined very well.

## 2.5 Intended use

- The ventilation unit is designed to ventilate living spaces and rooms used for quasi-residential purposes. It can also be installed in offices, surgeries, etc. The ventilation unit is installed in a perpendicular position in the external wall. Any different or more extensive usage will be regarded as contrary to the intended use.
- The intended use also includes compliance with all the notes in the operating instructions.
- The ventilation unit must not be operated without air filters or outer wall terminal.
- The ventilation unit is intended for use in rooms with normal room air humidity levels of approx. 40 % to 70 % RH. It must not be installed in rooms in which the relative humidity during operation constantly exceeds 80 %.
- The ventilation unit's functions may be impaired or the unit may be damaged in rooms with a lot of dust (e.g. model-making) or corrosive gas emissions (e.g. blueprint shop, cleaning).
- For any use contrary to the intended use, Meltem Wärmerückgewinnung GmbH & Co. KG shall accept no liability for any damage that may occur and offers no warranty that the ventilation unit will work perfectly and correctly.

## 3 Planning notes

### 3.1 Surface-mount installation

#### 3.1.1 Requirements for the installation wall

##### **⚠ WARNING**

##### **Danger from emerging gas or electric shock**

- ▶ Make sure that there are no supply lines in the vicinity of the wall breakthrough (e.g. power, gas or water).
- ▶ Make sure that the wall breakthrough does not affect the local static loading requirements.
- ▶ Fit a lintel if necessary.

The ventilation unit must be installed indoors in a perpendicular position on an external wall.

- The surface to which the ventilation unit will be fixed must be flat. Any unevenness will distort the housing when it is fixed in place, and may impair the unit's functioning.
- The external wall must consist of a suitable material (e.g. wooden panel, masonry) that offers a stable surface for fixing the ventilation unit.
- Surface-mount installation is possible even with very thin walls, e.g. installation on cladding panels. The minimum thickness will be determined by the outer wall terminal used:

Outer wall terminal	Minimum thickness of the wall or cladding panels
M-WRG-ES	50 mm
M-WRG-II KSR	40 mm

Table 2: Minimum thickness of the external wall

- ▶ For wall structures (including internal plaster, external render and insulation) that are 47 cm thick or more, you will need 100 cm long outdoor and exhaust air pipes (M-WRG-LR 100, part no. 5580).

#### 3.1.2 Positioning the ventilation unit indoors

- The ventilation unit must be installed so that the openings for extract air and supply air point up.
- For a standard room height of 2.50 m, the best effect for air exchange is achieved if the top edge of the unit with the supply and extract air openings is roughly 300 mm below the ceiling.
  - ▶ Maintain the following minimum distances (see Fig. 8 on page 13):
    - The distance between the top edge of the ventilation unit and the ceiling must be at least 150 mm to prevent an air short circuit.
    - The distance between the side and bottom edges of the unit and adjacent surfaces should be at least 50 mm. The ventilation unit will be easier to operate if this minimum distance is maintained. It also allows the air filter to be replaced without obstruction.

If a condensate connection (see section 10.4 on page 25) is used, the distance between the bottom edge of the unit and adjacent surfaces must be adapted to suit the local conditions. This applies, in particular, if condensate is drained inwards, e.g. via a greywater outlet.

- The lateral distance between two ventilation units must not be less than 200 mm to prevent an air short circuit.
- ▶ If the room height is greater than 2.50 m, position the ventilation unit so that the unit can be operated and filters can be maintained unaided (without steps, ladders, etc.). Alternatively you can order a ventilation unit that can be operated externally.

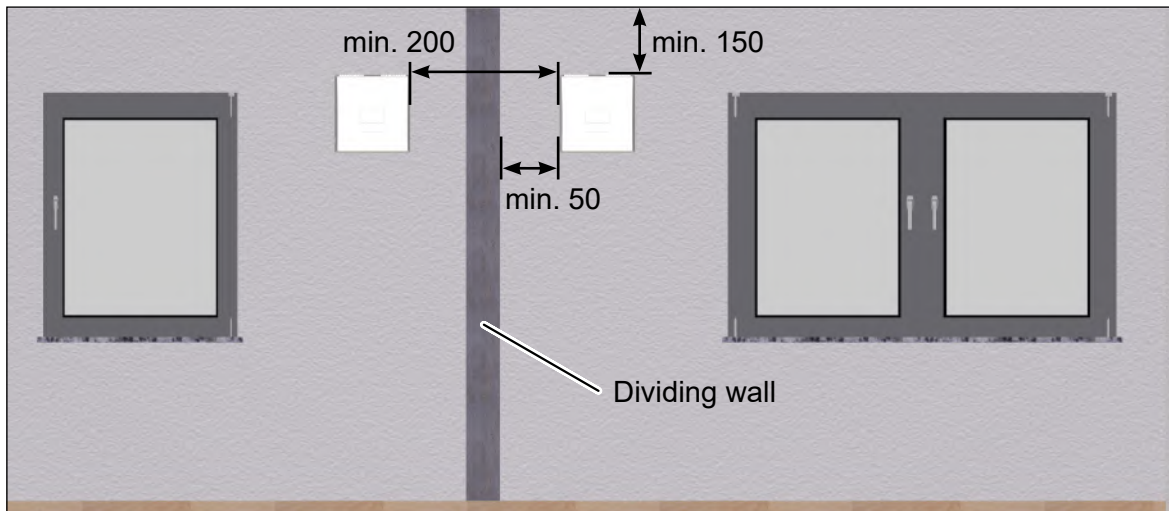

Fig. 8: Lateral minimum distance between two ventilation units, dimensions in millimetres

#### NOTICE

Follow the notes in Table 4 on page 29 when planning the unit. This contains information about the types of mains and control cable for each ventilation unit and the recommended operating options.

### 3.1.3 Unrestricted access to the ventilation unit

The ventilation unit must always be freely accessible for operation and maintenance.

- ▶ Make sure that the ventilation unit is not covered or obstructed when the room is subsequently decorated and furnished, otherwise it cannot be operated and it will not be possible to replace the air filters. You should therefore maintain a clearance of at least 15 cm in front of the ventilation unit cover.
- ▶ Make sure that the supply and extract air openings are not covered when the room is subsequently decorated and furnished, otherwise the ventilation unit's functions may be impaired.

### 3.1.4 Electrical connection

The working voltage range of the ventilation unit is between 85 V AC and 265 V AC / 50 - 60 Hz.

#### NOTICE

If the ventilation unit is not equipped with a mains connection cable and plug or other means of disconnecting from the mains supply that has, at each pole, a contact opening width that conforms to the conditions of overvoltage category III for complete separation, then such an isolating unit (e.g. circuit breaker) must be integrated into the permanently installed electrical system in accordance with the installation regulations. The isolating unit must be identified as such and easy to access.

### 3.2 Flush-mount installation

An M-WRG flush-mount installation kit is needed to flush-mount the ventilation unit (optionally with ductwork connection).

- ▶ Also read and follow the “Planning notes” section of the installation manual that is supplied with the flush-mount installation kit (see section “1.11 Supplementary documents” on page 8).

### 3.3 U<sup>2</sup> integrated into wall installation

An M-WRG U<sup>2</sup> installation kit is needed to integrate the ventilation unit into the wall.

- ▶ Also read and follow the “Planning notes” section of the installation manual that is supplied with the integrated into wall installation kit (see section “1.11 Supplementary documents” on page 8).

## **4 Warranty and liability**

### **4.1 Warranty**

The following cases shall invalidate the warranty:

- The installation kit was not installed as described in the installation manual.
- The ventilation unit was not installed as described in the installation manual.
- The ventilation unit was flush-mounted without using a flush-mount installation kit.
- Genuine parts/genuine air filters were not replaced with genuine parts.
- Unapproved changes were made to the installation kit or ventilation unit.
- Repairs were not carried out by Meltem or by an authorised specialist company.
- The ventilation unit was operated without air filters and outer wall terminals.
- The warranty does not cover wearing parts such as air filters.

### **4.2 Liability**

The manufacturer's liability shall not apply in the following cases:

- The installation kit was not installed as described in the installation manual.
- The ventilation unit was not installed as described in the installation manual.
- The ventilation unit was flush-mounted without using a flush-mount installation kit.
- Genuine parts/genuine air filters were not replaced with genuine parts.
- Unapproved changes were made to the installation kit or ventilation unit.
- Repairs were not carried out by Meltem or by an authorised specialist company.
- The ventilation unit was operated without air filters and outer wall terminals.

## 5 Dimensions

### 5.1 Ventilation unit without duct adapters

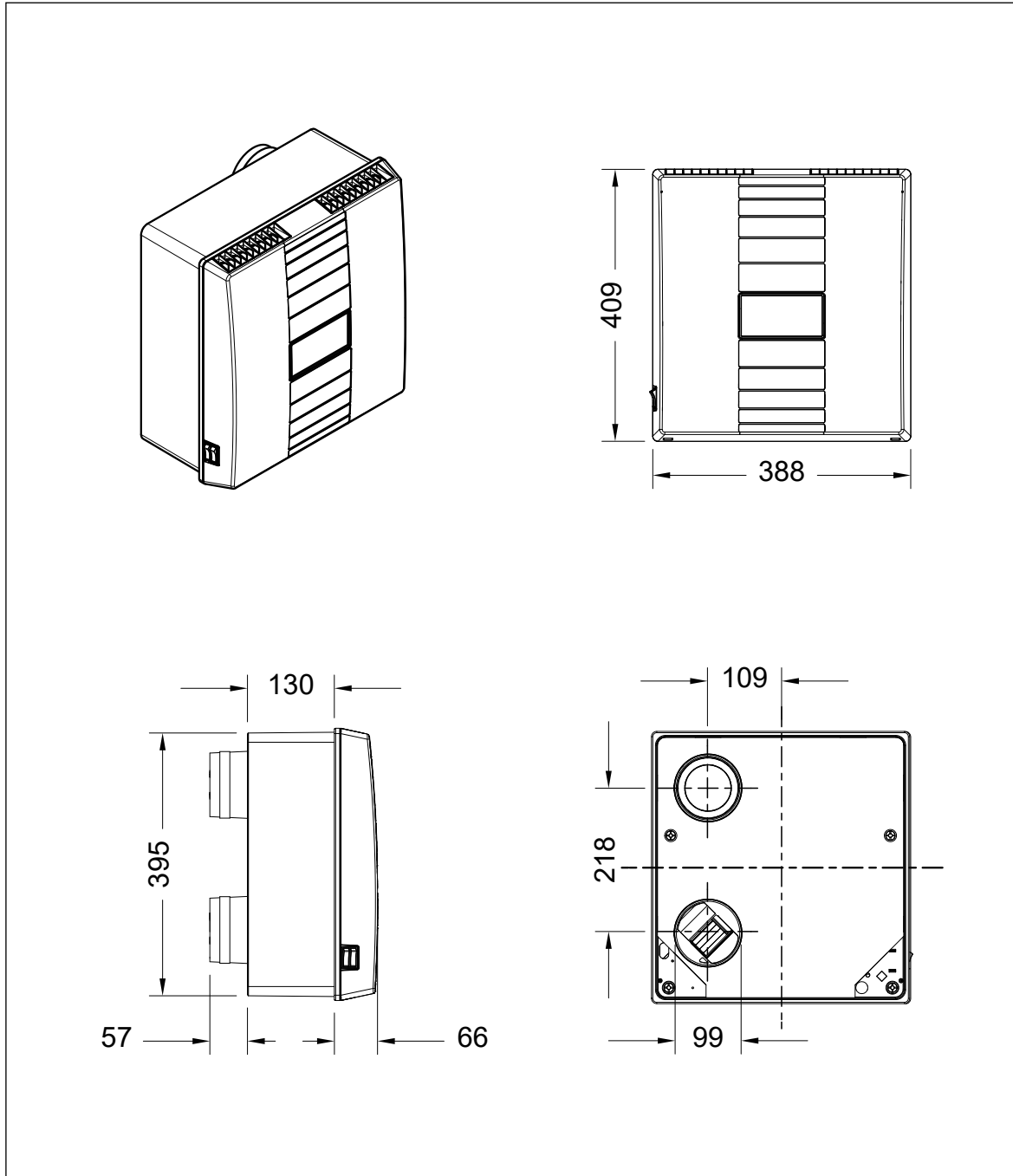

Fig. 9: M-WRG-S... ventilation unit without duct adapters, dimensions in millimetres



## 5.2 Ventilation unit with duct adapters for surface-mount and U<sup>2</sup> integrated into wall installation

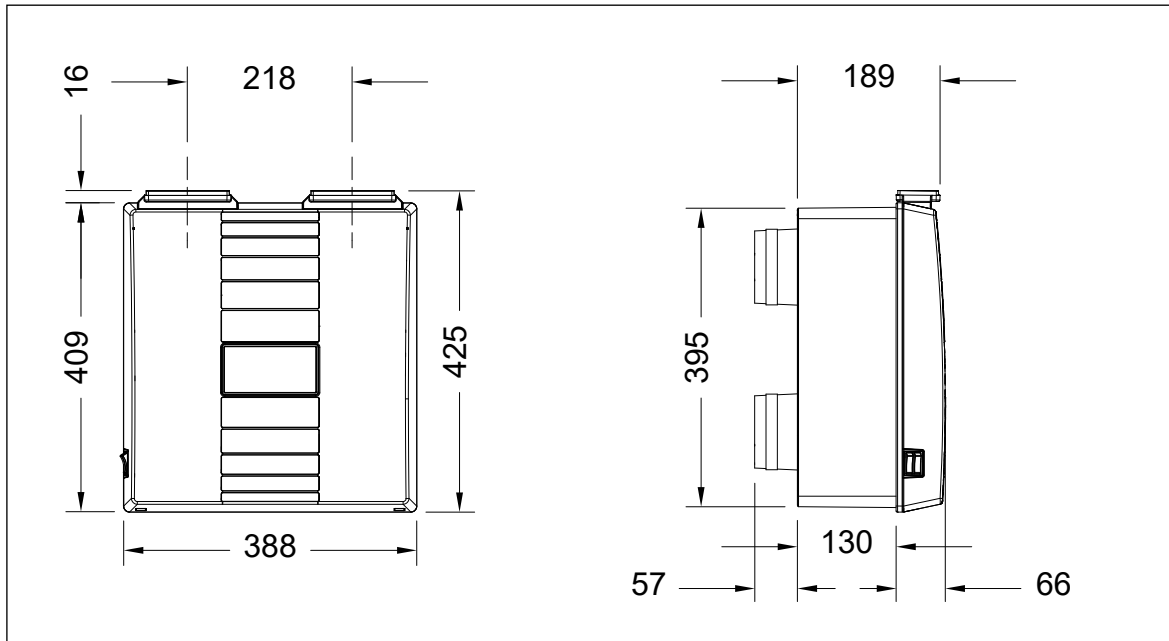

Fig. 10: M-WRG-S... ventilation unit with duct adapters for surface-mount and U<sup>2</sup> integrated into wall installation, dimensions in millimetres

## 5.3 Ventilation unit with duct adapters for flush-mount installation

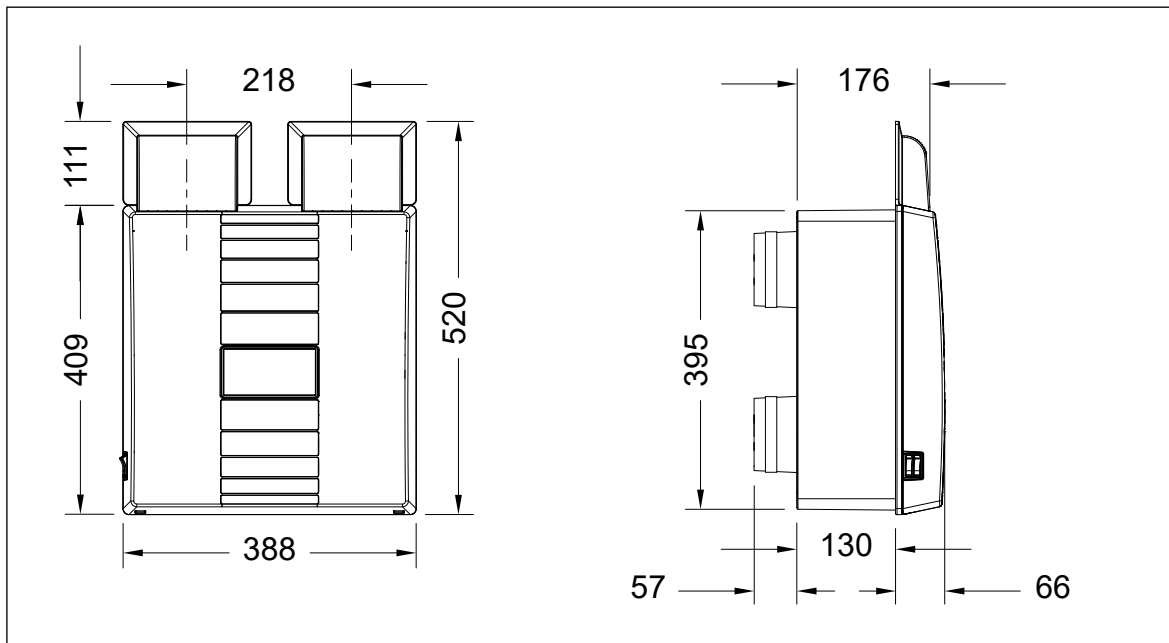

Fig. 11: M-WRG-S... ventilation unit with duct adapters for flush-mount installation, dimensions in millimetres

## 6 Items supplied

### 6.1 M-WRG-S... ventilation unit

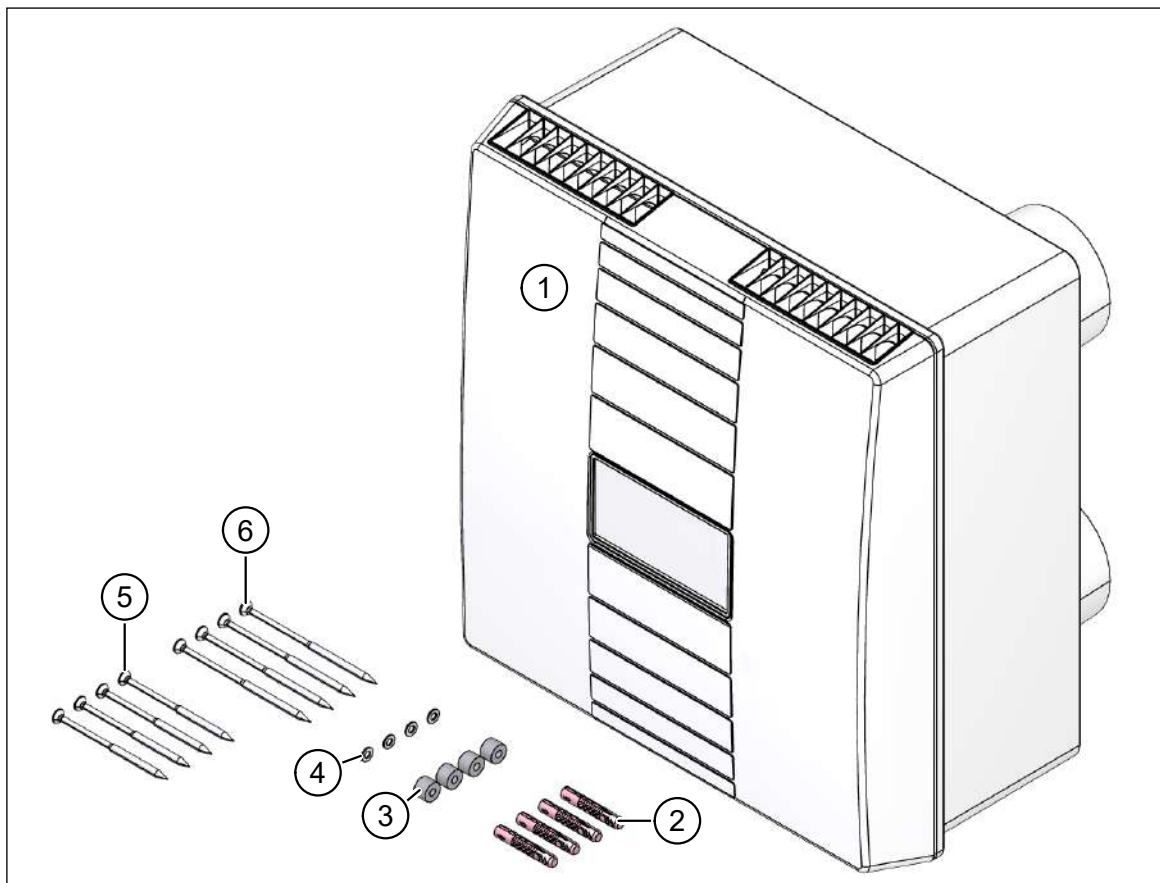

Fig. 12: Items supplied with the M-WRG-S... ventilation unit

Item	Description	Quantity
1	Ventilation unit	1 x
2	Dowel S8	4 x
3	Centring guide	4 x
4	Washer 5.3 x 10 mm	4 x
5	Cross-head screw 5 x 100 mm for flush-mount installation	4 x
6	Cross-head screw 5 x 120 mm for surface-mount installation	4 x
-	Operating instructions	1 x
-	Installation manual	1 x
-	Installation manual for connecting the control cable, depending on the type of ventilation unit	1 x

## 6.2 Installation materials required

Additional installation materials are needed for surface-mount, flush-mount with ductwork connection and U<sup>2</sup> integrated into wall installation. These must be ordered separately.

### 6.2.1 Surface-mount installation

Type	Part no.	Description
M-WRG-M/AP	5062	<ul style="list-style-type: none"> <li>— Surface-mount installation kit consisting of drilling templates for unit and outer wall terminal stainless steel pod, includes outdoor air and exhaust air pipe DN 100, 2 x 0.5 m</li> <li>— If a condensate connection is used: exhaust air pipe with 1/2" male thread condensate connection (type M-WRG-II LR 50-KA, part no. 735200)</li> </ul>
M-WRG-KA	5374	<p>For surface-mount installation with ductwork connection only:</p> <p>Duct adapter for ductwork connection to another room when running surface-mount flat ductwork, for surface-mount units, connection via fitting with sleeve or flat ductwork bracket M-WRG-FK-W</p>

### 6.2.2 Flush-mount installation with ductwork connection

Type	Part no.	Description
M-WRG-KA/UP	5365	Duct adapter for flush-mount M-WRG units, one or two ductwork connections possible, for flush-mounting flat ductwork or flexible pipe

### 6.2.3 U<sup>2</sup> integrated into wall installation

Type	Part no.	Description
M-WRG-U <sup>2</sup> AK	5052-90	U <sup>2</sup> adapter kit, needed to install the M-WRG units in the U <sup>2</sup> installation kit
M-WRG-U <sup>2</sup> AD/WS-2	5052-10-04	U <sup>2</sup> cover

## 7 Overview of the modules

### 7.1 Ventilation unit – with unit cover attached

Item	Designation
1	Housing
2	Unit cover
3	Stepping switch for three power levels + intensive ventilation level
4	Mains switch

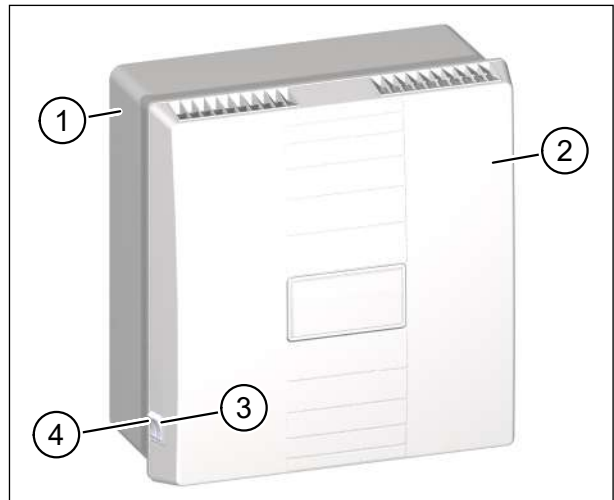

Fig. 13: Ventilation unit – unit cover attached

### 7.2 Ventilation unit – with unit cover removed

Item	Designation
1	Supply air opening with air flap
2	Supply air filter with filter cover
3	Intermediate plate
4	Network connection cover
5	Supply air hood
6	Extract air filter with filter ring
7	Extract air opening with air flap

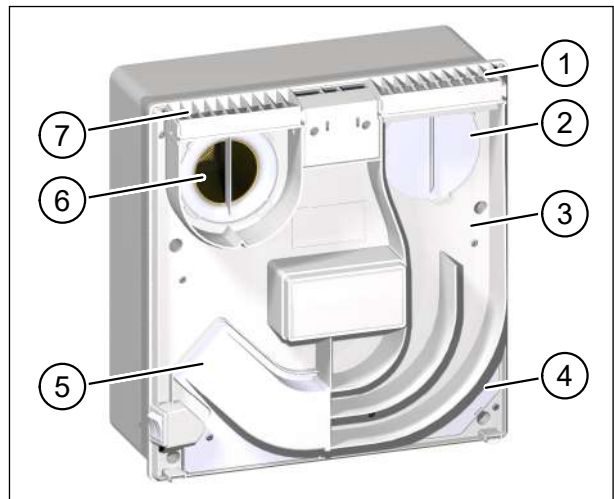

Fig. 14: Ventilation unit – unit cover removed

### 7.3 Outer wall terminal

Fig. 15 shows the outer wall terminal M-WRG-ES by way of example.

Item	Designation
1	Opening for drawing in outdoor air
2	Opening for blowing out exhaust air

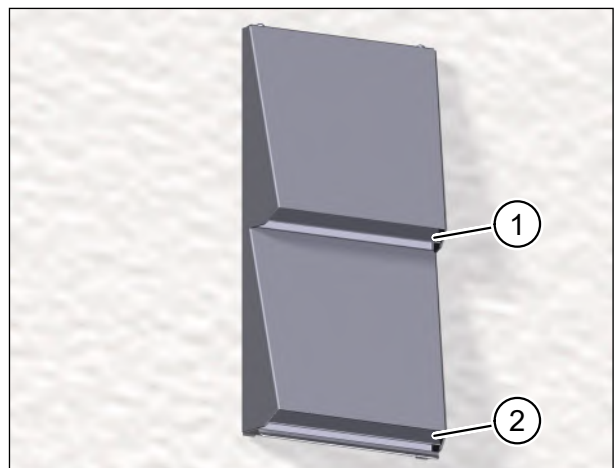

Fig. 15: Outer wall terminal

## 8 Tools and equipment required

### 8.1 Surface-mount installation

- Adhesive tape for fixing the drilling template
- Core drill Ø 120 mm
- Expanding foam with abP (national technical test certificate of the DIBt) approval (“exact gap” foam is recommended)
- Hammer drill with 8 mm masonry bit
- Material for closing off the ventilation pipes for plastering (e.g. paper)
- Saw for cutting the ventilation pipes to length
- Set of cross-head screwdrivers
- Set of slotted screwdrivers
- Spirit level
- Torx screwdriver TX20
- Wall chaser

### 8.2 Flush-mount installation

- Set of cross-head screwdrivers
- Set of slotted screwdrivers
- Torx screwdriver TX20

### 8.3 U<sup>2</sup> integrated into wall installation

- Set of cross-head screwdrivers
- Set of slotted screwdrivers
- Torx screwdriver TX20
- Washing-up liquid or Vaseline

## 9 General installation instructions

### NOTICE

- The installation must be carried out in accordance with the generally acknowledged rules of technology.
- Connections with adjacent components must be formed to absorb movements between the contact surfaces.
- Seal any connections that are exposed to driving rain with tapes, profiles or sealants such that they offer sufficient protection against the expected conditions.

### ⚠ WARNING

#### Follow the relevant accident prevention regulations

- ▶ Follow the accident prevention regulations when setting up the installation location.
- ▶ Protect the outside area against falling parts.

## 9.1 Surface-mount installation / flush-mount installation / U<sup>2</sup> integrated into wall installation

This manual describes the surface-mount and flush-mount installation of the ventilation unit.

- For **surface-mount installation**, follow the steps in sections “10 Surface-mount installation” from page 23 and “11 Installing the ventilation unit” from page 33.
- For **flush-mount installation (optionally with ductwork connection)**, follow the steps in section “11 Installing the ventilation unit” from page 33.  
The ventilation unit is installed once the work described in the installation manuals for the flush-mount installation kit is complete (see section “1.11 Supplementary documents” on page 8).
- For **U<sup>2</sup> integrated into wall installation** follow the steps in section “11 Installing the ventilation unit” from page 33.  
The ventilation unit is installed once the work described in the installation manual for the U<sup>2</sup> flush-mount installation kit is complete (see section “1.11 Supplementary documents” on page 8).

## 9.2 Electrically disconnecting mains cables

During installation, the ventilation unit is connected to the power supply with a mains cable.

### **DANGER**

#### **Potentially fatal voltages**

- The electrical installation work must only be carried out by a qualified electrician.
- The VDE regulations or any special safety regulations applicable in your country apply to the electrical installation work.
- ▶ Before starting installation or maintenance work, disconnect the mains cable for connecting to the ventilation unit on all poles from the mains supply.
- ▶ Observe the five safety rules (DIN VDE 0105-100, EN 50110-1) for working on electrical systems:
  - Disconnect from mains (all-pole disconnection of a system from live parts)
  - Secure against reconnection
  - Check that the system is voltage-free
  - Earth and short-circuit
  - Cover or block off access to adjacent live parts

## 10 Surface-mount installation

### 10.1 Marking positions of core drill holes with drilling template

- ▶ Press the pre-punched cut-outs (item 2 in Fig. 16) for the core drill holes out of the drilling template.
- ▶ Position the drilling template (item 3 in Fig. 16) at the installation location on the internal wall.

#### NOTICE

Observe the required distances of roughly 300 mm (at least 150 mm) from the ceiling and at least 50 mm from the side wall.

- ▶ Use the spirit level to align the drilling template (item 1 in Fig. 16).
- ▶ Fix the drilling template in place with adhesive tape (item 4 in Fig. 16).
- ▶ Using the spirit level, check again that the drilling template is aligned.
- ▶ Mark the outlines (item 1 in Fig. 17) of the pre-punched contours for the core drill holes on the internal wall.
- ▶ Mark the six notches (item 2 in Fig. 17) of the drilling template on the internal wall.
- ▶ Remove the drilling template.
- ▶ Draw the cross-hairs (item 3 in Fig. 17) for the core drill holes using the six marked notches.
- ▶ Check the marks for the core drill holes against Fig. 17.

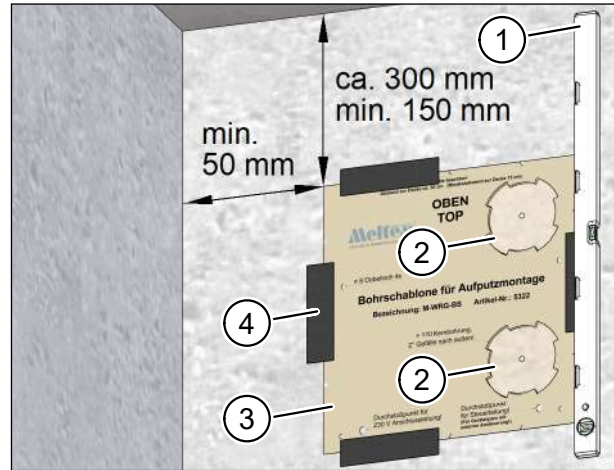

Fig. 16: Marking positions of the core drill holes

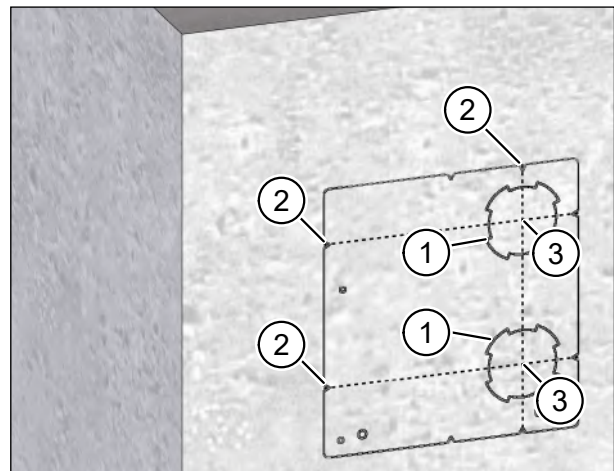

Fig. 17: Marks on the internal wall

## 10.2 Drilling core drill holes

- ▶ Drill the two Ø 120 mm core drill holes as described in Fig. 18.

### NOTICE

Be sure to align the core drill holes with the necessary 2° drop from the inside to the outside of the wall. This is the only way to ensure that any condensation is dissipated via the exhaust air pipe.

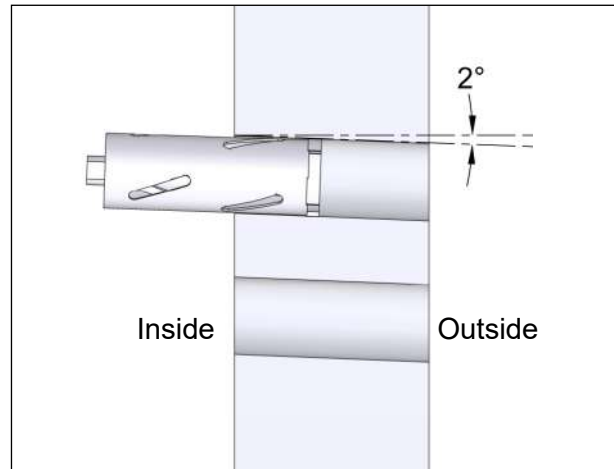

Fig. 18: Drilling core drill holes

## 10.3 Drilling holes for dowels and making marks for connecting cables

- ▶ Position the drilling template (item 1 in Fig. 19) precisely over the two core drill holes.
- ▶ Mark the four holes (item 2 in Fig. 19) for the dowels for fixing the ventilation unit to the internal wall.
- ▶ Mark the position of the cable outlet for the mains cable (item 4 in Fig. 19) of the ventilation unit. This mark identifies the end of the wall channel that needs to be chased out for the mains cable.
- ▶ Mark the position of the cable outlet for the control cable (if used) (item 3 in Fig. 19) of the ventilation unit (only for ventilation units with a control cable connection, see Table 4 on page 29). This mark identifies the end of the wall channel that needs to be chased out for the control cable.
- ▶ Remove the drilling template again.
- ▶ Drill four holes for the dowels Ø 8 mm and 60 mm deep.

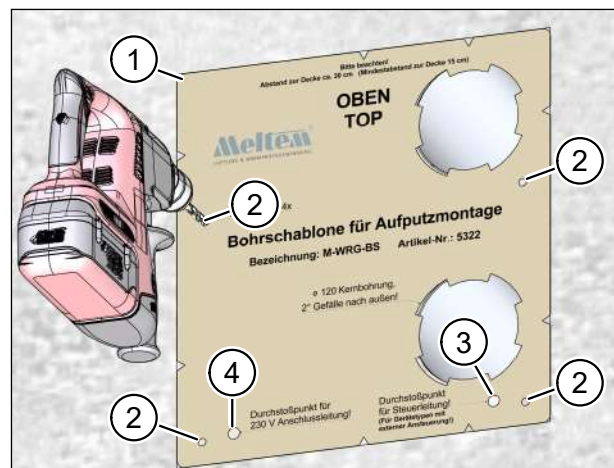

Fig. 19: Holes for dowels and marks for connecting cables



## 10.4 Condensate drain on the exhaust air pipe

If M-WRG ventilation units are used, a condensate drain should be provided under certain circumstances (see section 2.2.4 on page 10). The M-WRG-II LR 50-KA set, part no. 735200, with the following components may be used for this purpose:

- Outdoor air pipe, DN 100, 0.5 m (item 1 in Fig. 20)
- Exhaust air pipe, DN 100, 0.5 m (item 2 in Fig. 20), with 1/2" male thread connection (item 3 in Fig. 20) and barrier (item 4 in Fig. 20) for retaining the condensate.

### NOTICE

Note the following points when creating the condensate connection:

- The condensate drain is to be created by the customer.
- Prevent odour transfer by installing an odour trap.
- If possible, connect the condensate drain to a grey water or rainwater discharge.
- In cold regions, protect the condensate drain pipe (item 5 in Fig. 20) against frost, e.g. by running it behind the facade insulation.

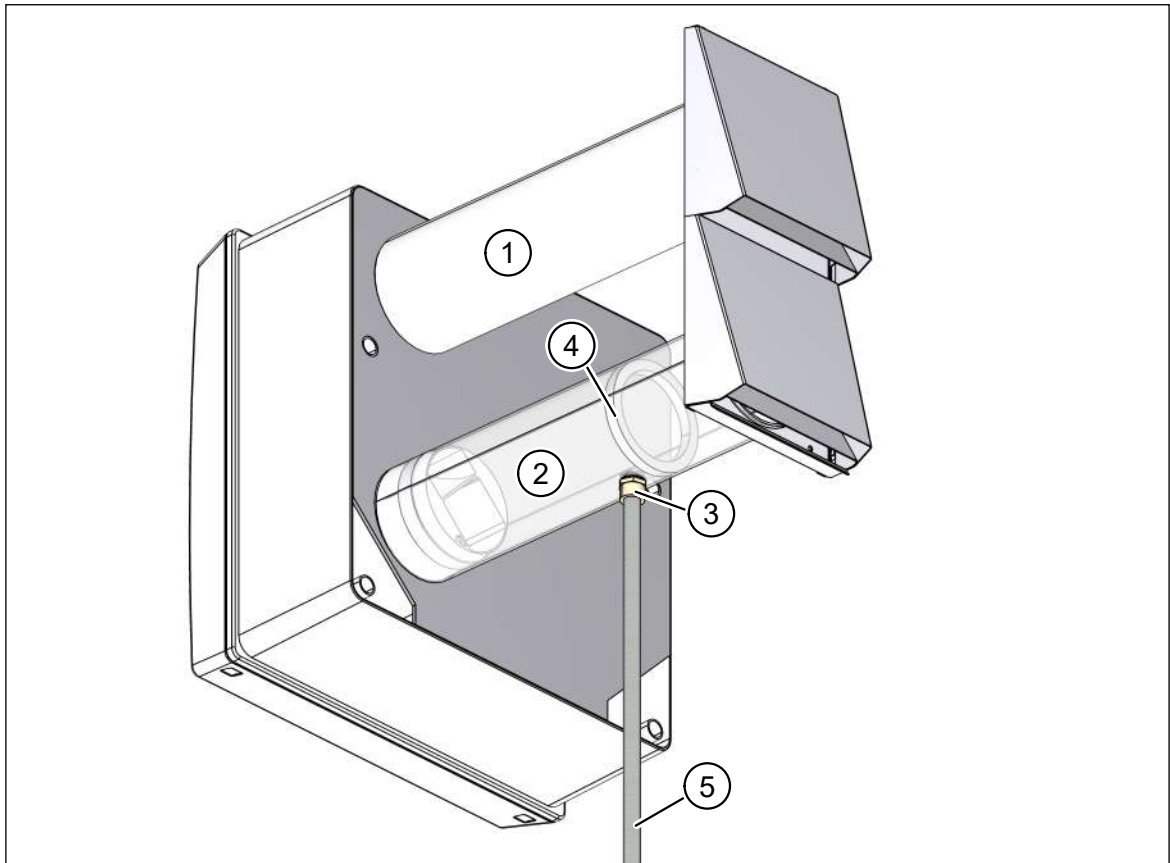

Fig. 20: Condensate drain on the exhaust air pipe

## 10.5 Chasing out channels for connecting cables

- ▶ Chase out a wall channel for the mains cable starting from the cable passage (item 1 in Fig. 21).
- ▶ Chase out a wall channel for the control cable (if used) starting from the cable passage (item 2 in Fig. 21) (only for ventilation units with a control cable connection, see Table 4 on page 29).
- ▶ Position the drilling template (item 2 in Fig. 22) on the internal wall.
- ▶ Fix the drilling template in place with the four S8 dowels (item 3 in Fig. 22).
- ▶ Use the spirit level to align the drilling template and fix the drilling template in place with adhesive tape.

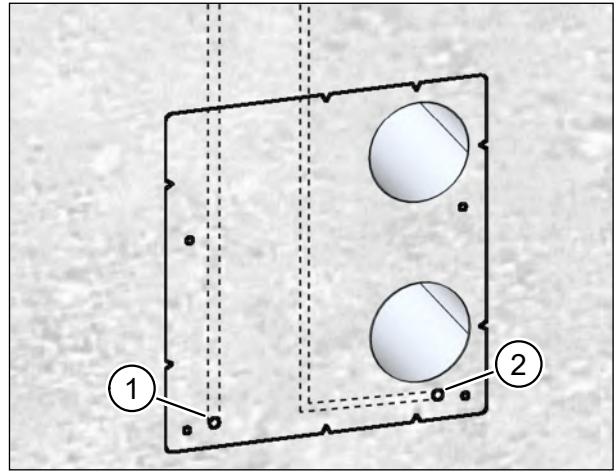

Fig. 21: Chasing wall channel for the mains cable and control cable (if used)

## 10.6 Inserting the ventilation pipes

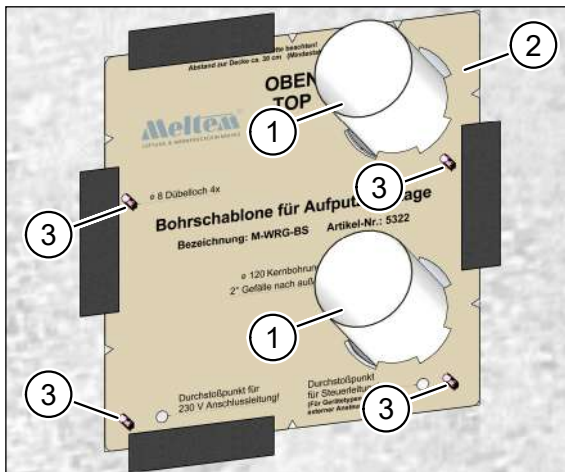

Fig. 22: Ventilation pipes on the inside of the wall

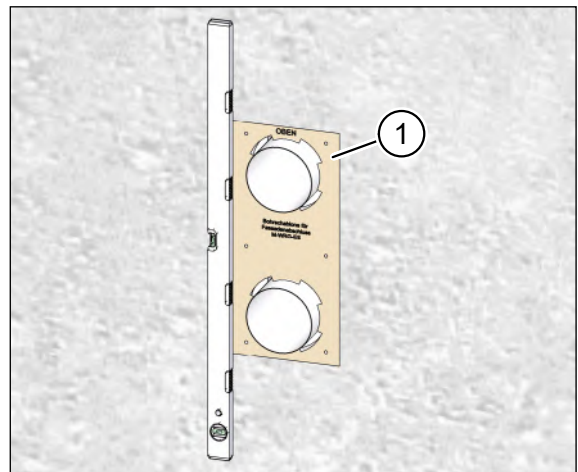

Fig. 23: Ventilation pipes on the outside of the wall

### NOTICE

Prepare the breakthrough surfaces suitably for the ventilation pipes.

- ▶ Push the two ventilation pipes (item 1 in Fig. 22) through the core drill holes so that they protrude on both the inside and the outside of the wall. The ventilation pipes are fixed in place on the inside of the wall by the drilling template for the ventilation unit (item 2 in Fig. 22).
- ▶ Push the drilling template for the outer wall terminal (item 1 in Fig. 23) over the ventilation pipes.
- ▶ Align the drilling template for the outer wall terminal so that the ventilation pipes run with a 2° drop from inside to outside.

## NOTICE

Be sure to align the core drill holes with the necessary 2° drop from the inside to the outside of the wall. This is the only way to ensure that any condensation is dissipated via the exhaust air pipe.

- ▶ Use the spirit level to align the drilling template for the outer wall terminal.

## 10.7 Drilling the holes for the outer wall terminal

- ▶ Drill the holes for the outer wall terminal.
- ▶ Fix the drilling template in place with the dowels and screws provided.
- ▶ Check the required excess length of the ventilation pipes protruding from the external wall with reference to the following table (depending on the outer wall terminal, see also the installation manual for the outer wall terminals in section 1.11 on page 8):

Outer wall terminal	Excess length
Stainless steel pod, M-WRG-ES	5 - 10 mm from the plastered external wall
Plastic pipe set, M-WRG-II KSR	20 - 27 mm from the plastered external wall

Table 3: Excess length of ventilation pipes protruding from the external wall

- ▶ If necessary, correct the excess length by moving the ventilation pipe.

## 10.8 Fixing ventilation pipes and filling gaps with foam

- ▶ Spray expanding foam through the recesses (item 1 in Fig. 24) in the drilling templates on the inside and outside of the wall in order to provisionally fix the ventilation pipes.
- ▶ Check the position of the ventilation pipes again.

## NOTICE

Be sure to align the core drill holes with the necessary 2° drop from the inside to the outside of the wall. This is the only way to ensure that any condensation is dissipated via the exhaust air pipe.

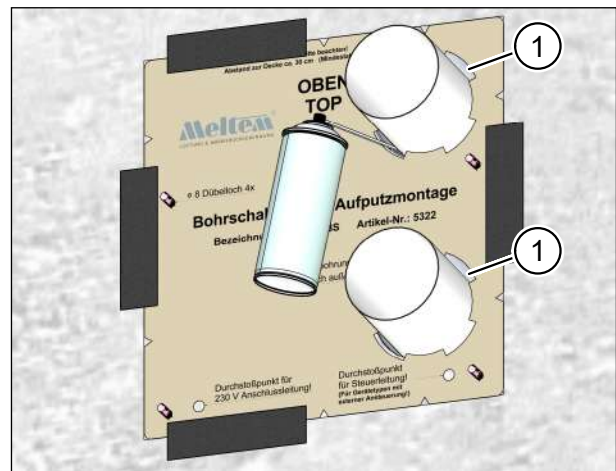

Fig. 24: Fixing the ventilation pipes

- ▶ Wait until the expanding foam has cured.
- ▶ Remove the drilling templates from the inside and outside of the wall.
- ▶ Completely fill the cavities between the core drill holes and ventilation pipes with expanding foam.
- ▶ Wait until the expanding foam has cured.

## 10.9 Running the connecting cables

### **⚠ DANGER**

#### **Potentially fatal voltages**

- The electrical installation work must only be carried out by a qualified electrician.
- The VDE regulations or any special safety regulations applicable in your country apply to the electrical installation work.
- ▶ Before starting installation or maintenance work, disconnect the mains cable for connecting to the ventilation unit on all poles from the mains supply.
- ▶ Observe the five safety rules (DIN VDE 0105-100, EN 50110-1) for working on electrical systems:
  - Disconnect from mains (all-pole disconnection of a system from live parts)
  - Secure against reconnection
  - Check that the system is voltage-free
  - Earth and short-circuit
  - Cover or block off access to adjacent live parts

- ▶ Run the mains cable (item 1 in Fig. 25) and the control cable (if used) (item 2 in Fig. 25). The cables should extend roughly 250 mm beyond the wall.
- ▶ Fix the mains cable and the control cable (if used) in position.

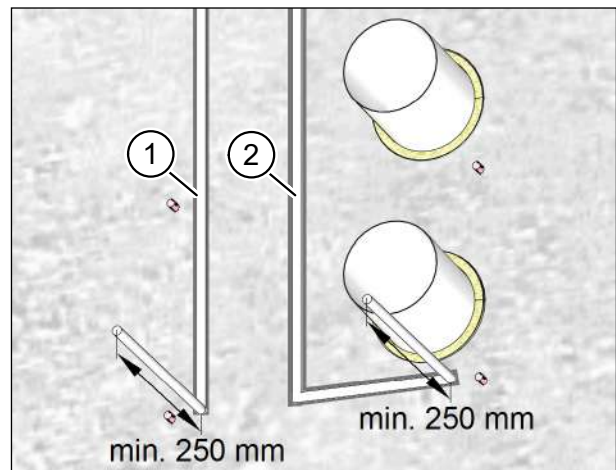

Fig. 25: Running the connecting cables

### **NOTICE**

- Table 4 on page 29 contains an overview of the recommended types of mains cable and control cable.
- A control cable is only needed for certain types of ventilation unit.
- The ventilation unit is equipped with an external control input as standard. The mains cable **NYM-J 4x1.5 mm<sup>2</sup>** is needed if this control input is used.

### 10.9.1 Cable types

Part no.	Type of ventilation unit	Type of mains cable	Type of control cable
5010 (*)	M-WRG-S	NYM-J 3x1.5 mm <sup>2</sup> or NYM-J 4x1.5 mm <sup>2</sup> (**)	No control cable
5016-1-0	M-WRG-S/Z-S	NYM-J 3x1.5 mm <sup>2</sup> or NYM-J 4x1.5 mm <sup>2</sup> (**)	J-Y (St) Y 4 x 2 x 0.6 mm / J-Y (St) Y 4 x 2 x 0.8 mm
5016-1-1 5016-1-1-1 5016-1-1-2	M-WRG-S/Z-T M-WRG-S/Z-T-F M-WRG-S/Z-T-FC	NYM-J 3x1.5 mm <sup>2</sup> or NYM-J 4x1.5 mm <sup>2</sup> (**)	J-Y (St) Y 10x2x0.6 mm / J-Y (St) Y 10x2x0.8 mm
5012 5012-1 5012-2	M-WRG-S M M-WRG-S M-F M-WRG-S M-FC	NYM-J 3x1.5 mm <sup>2</sup> or NYM-J 4x1.5 mm <sup>2</sup> (**)	Building management system, Modbus, Loxone, KNX: J-Y (St) Y 2x2x0.6 mm / J-Y (St) Y 2x2x0.8 mm
5013 5014-1 5014-2	M-WRG-S 485 M-WRG-S 485-TF M-WRG-S 485-TFC	NYM-J 3x1.5 mm <sup>2</sup> or NYM-J 4x1.5 mm <sup>2</sup> (**)	Touch Control network: J-Y (St) Y 2x2x0.6 mm / J-Y (St) Y 2x2x0.8 mm

Table 4: Types of mains cable and control cable for each ventilation unit type

(\*) If you install these types of ventilation unit in the M-WRG-M/MB-U<sup>2</sup> installation kit, we recommend that you use the following options to operate the ventilation units:

- Using the app via the gateway M-WRG-GW, part no. 5453-00
- Wireless remote control M-WRG-FBH, part no. 5478-10
- 4-way wireless pushbutton switch M-WRG-FT, part no. 5478-20
- External wireless humidity sensor M-WRG-II FSF, part no. 733010
- External wireless CO<sub>2</sub> sensor M-WRG-II FSC, part no. 733011

(\*\*) If the external control input is used

### 10.9.2 External control input

With the external control input supplied as standard, the M-WRG unit has an additional input terminal for 230 V AC (working voltage range: 85 V AC to 265 V AC / 50 - 60 Hz) to which a switch, time switch, motion detector or similar may be connected.

The external control input is equipped with a time-delay relay that can be used to set a switch-on delay and a run-on time:

- Switch-on delay: the M-WRG unit does not start until the set time has elapsed.
- Run-on time: the M-WRG unit does not switch to the previously active ventilation program until the set time has elapsed.

In addition, the following options are available for the external control input supplied as standard:

- M-WRG-O/EST-1 (without switch-on delay, part no. 5046-31)
- M-WRG-O/EST-2 (without run-on time, part no. 5046-32)

Windowless rooms can be ventilated in accordance with DIN 18017-3 in combination with the M-WRG-O/NOF option (part no. 5046-10).

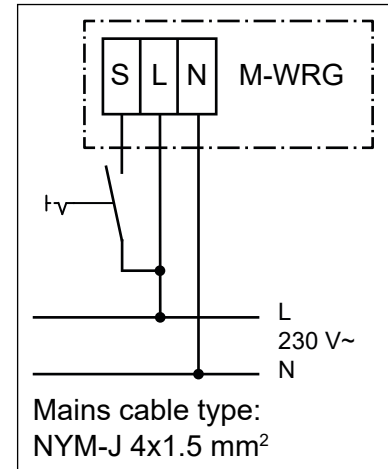

Fig. 26: Connection diagram for external control input

## 10.10 Plastering the internal wall

### NOTICE

Prepare the substrate suitably before plastering.

- ▶ Before plastering, close off both ends of the ventilation pipes with adhesive tape (item 1 in Fig. 27) or another suitable material.
- ▶ Trim the expanding foam (item 2 in Fig. 27) flush with the unplastered wall.
- ▶ Plaster the cable ducts.
- ▶ Plaster the internal wall as far as the ventilation pipes.

The plaster forms the airtight layer on the internal wall. The expanding foam does not act as an airtight layer.

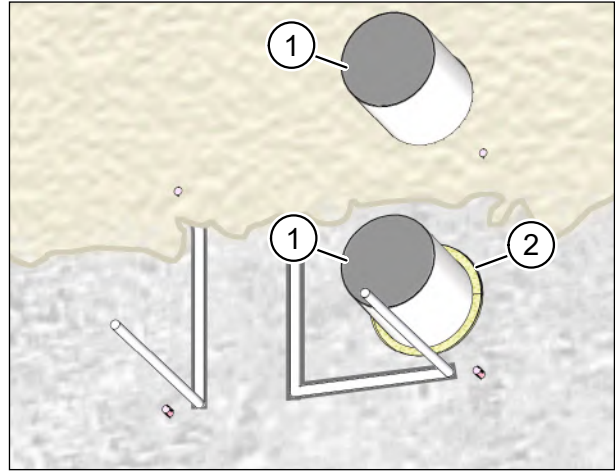

Fig. 27: Plastering the internal wall

### NOTICE

When the ventilation unit is subsequently surface-mounted, the internal wall is already plastered.

- ▶ In this case, remove the expanding foam as far as the unplastered wall and then plaster the gap around the ventilation pipe. The plaster forms the airtight layer on the internal wall. The expanding foam does not act as an airtight layer.

## 10.11 Cutting ventilation pipes on internal wall to length

- ▶ Cut the ventilation pipes (item 1 in Fig. 28) to length on the internal wall so that they end flush with the internal plaster.
- ▶ Deburr the ventilation pipes on the internal wall.

### NOTICE

If you do not deburr the ventilation pipes there is a risk of damaging the seals at the ventilation unit.

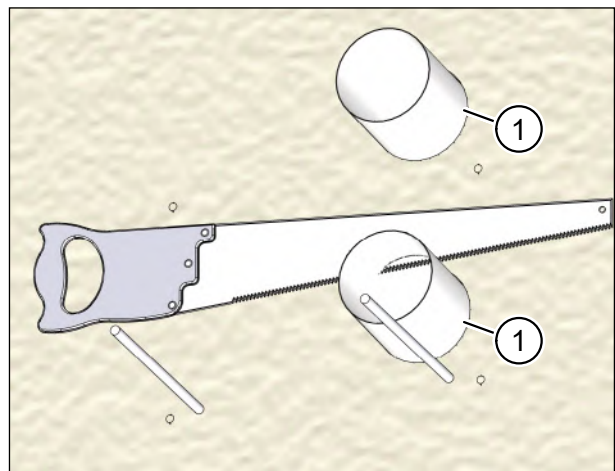

Fig. 28: Cutting ventilation pipes on internal wall to length

## 10.12 Sealing ventilation pipes on external wall

### NOTICE

If the external plaster encloses the ventilation pipes all round and without gaps, you can skip the steps described in this section.

- ▶ Chamfer both pipe breakthrough edges (item 1 in Fig. 29) to roughly  $5 \times 45^\circ$  to create enough space for the sealing joints with permanently elastic sealant.
- ▶ Fill the chamfers of the pipe breakthrough edges all-round with permanently elastic sealant on the outside.

### NOTICE

Only use a solvent-free sealant if the sealant is applied to polystyrene.

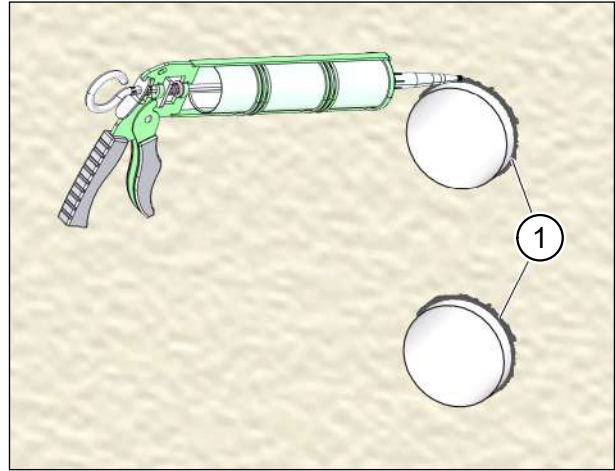

Fig. 29: Sealing ventilation pipes on the external wall

## 10.13 Attaching the outer wall terminal

### ⚠ WARNING

#### Do not run without the outer wall terminal

Please note that the ventilation unit must not be used without the outer wall terminal for safety reasons.

- ▶ Attach the outer wall terminal to the external wall.

### NOTICE

Installation of the outer wall terminal is described in a separate installation manual (see "1.11 Supplementary documents" on page 8).



Fig. 30: Attaching the outer wall terminal



## 11 Installing the ventilation unit

### 11.1 Removing the unit cover from the ventilation unit

- ▶ Using both thumbs, press the two latches (item 1 in Fig. 31) on the bottom of the ventilation unit. The unit cover will come away.
- ▶ At the same time, push your index fingers into the gap between the unit cover and housing, and lift the unit cover away from the housing.

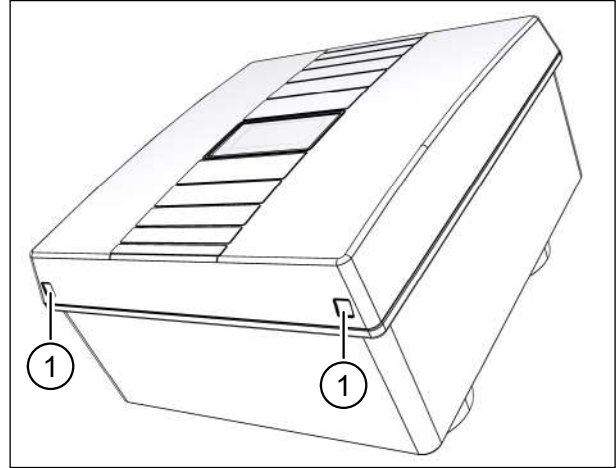

Fig. 31: Removing the unit cover from the ventilation unit

### 11.2 Checking the seals around the air spigots

- ▶ Check that the seals (item 1 in Fig. 32) around the air spigots on the back of the ventilation unit are undamaged. Damaged seals should be replaced immediately.

#### NOTICE

For ease of installing the unit (see section 11.7 on page 36), you can apply washing-up liquid or Vaseline to the seals (item 1 in Fig. 32) on the air spigots.

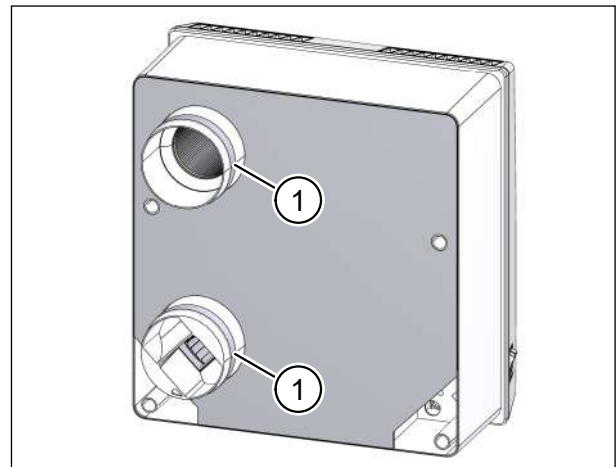

Fig. 32: Checking the seals around the air spigots

### 11.3 Inserting fixing screws with centring guides into the ventilation unit

- ▶ Take the four 5 x 100 mm or 5 x 120 mm cross-head screws, four washers and four centring guides (see Fig. 12 on page 18) from the ventilation unit set.

#### NOTICE

Note the following points when selecting the cross-head screws:

- Use the **5 x 120 mm** long cross-head screws for **surface-mount installation**.
- Use the **5 x 100 mm** long cross-head screws for **flush-mount (optionally with ductwork connection) or U<sup>2</sup> integrated into wall installation**.

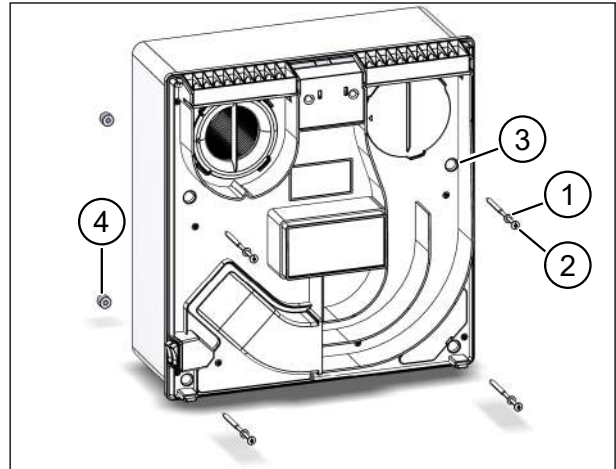

Fig. 33: Inserting the fixing screws

- ▶ Place the washers (item 1 in Fig. 33) on the cross-head screws (item 2 in Fig. 33) and introduce them into the holes in the housing (item 3 in Fig. 33).
- ▶ Screw the four centring guides (item 4 in Fig. 33) onto the four cross-head screws at the back until the tip of each cross-head screw protrudes roughly 10 mm over the centring guide.

### 11.4 Removing the supply air hood

- ▶ Use the screwdriver to loosen the screw (item 1 in Fig. 34) on the supply air hood (item 2 in Fig. 34).
- ▶ Hold the supply air hood by the curved walls and press against the pressure point (item 3 in Fig. 34). This will release the latch connection and you can now remove the supply air hood.

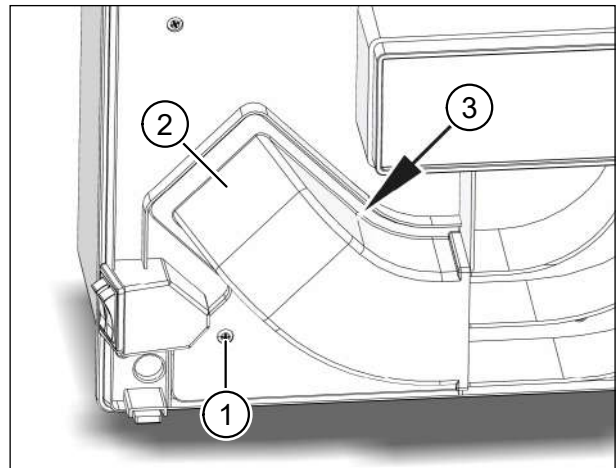

Fig. 34: Removing the supply air hood

## 11.5 Removing the network connection cover (on certain ventilation unit types only)

### NOTICE

The network connection cover only has to be removed when connecting a control cable to the ventilation unit. You will find the affected ventilation units in Table 4 on page 29.

- ▶ Press the latch (item 1 in Fig. 35) of the network connection cover (item 2 in Fig. 35) gently towards the middle of the unit, and lift up the network connection cover.

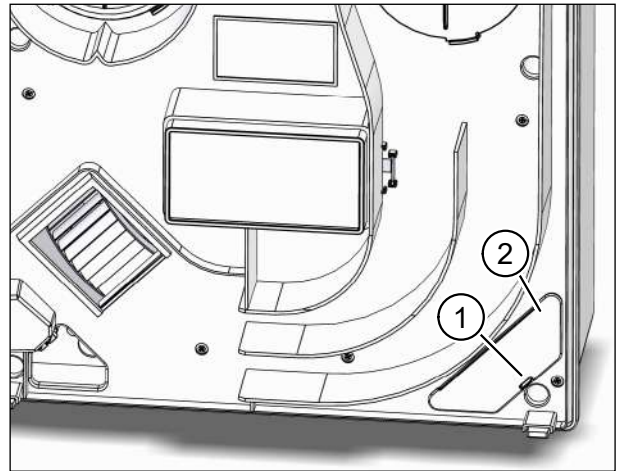

Fig. 35: Removing the network connection cover

## 11.6 Threading in cables through the opening

- ▶ Hold the ventilation unit in front of the installation location.
- ▶ Thread the mains cable into the opening (item 1 in Fig. 36) on the ventilation unit and pull the cable through the opening.
- ▶ Thread the control cable (if used) into the opening (item 2 in Fig. 36) on the ventilation unit and pull the cable through the opening.

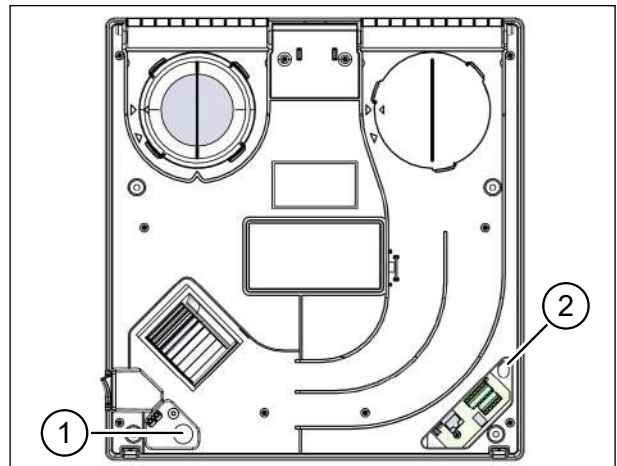

Fig. 36: Threading in the mains cable and control cable (if used)

## 11.7 Fixing the ventilation unit

### 11.7.1 Surface-mount installation

- ▶ Attach the ventilation unit so that the air spigots are lined up with the outdoor air pipe (item 1 in Fig. 37) and exhaust air pipe (item 2 in Fig. 37).
- ▶ Carefully push the ventilation unit as far as it will go against the wall.
- ▶ Use the four 5 x 120 mm cross-head screws (item 3 in Fig. 37) to fix the ventilation unit in the dowels (item 4 in Fig. 37) on the wall. **Lightly** tighten the screws using a diagonal sequence.

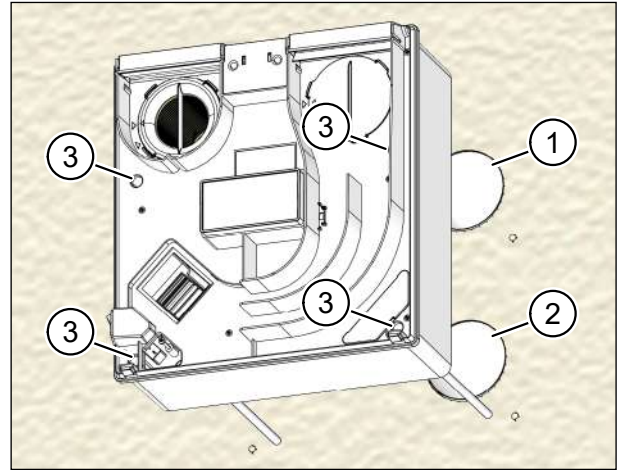

Fig. 37: Fixing the ventilation unit – surface-mount installation

#### NOTICE

- ▶ Use a spirit level to align the ventilation unit.

- ▶ Tighten the cross-head screws using a diagonal sequence.

### 11.7.2 Flush-mount installation

- ▶ Carefully push the ventilation unit as far as it will go into the wall box (item 1 in Fig. 38).
- ▶ Use the four 5 x 100 mm cross-head screws (item 2 in Fig. 38) to fix the ventilation unit. **Lightly** tighten the screws using a diagonal sequence.
- ▶ Tighten the cross-head screws using a diagonal sequence.

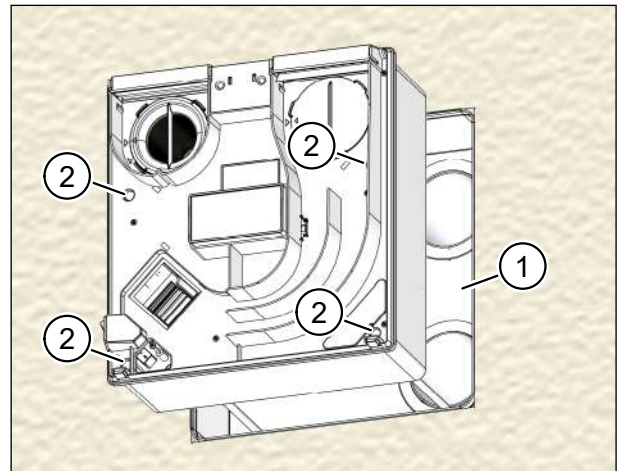

Fig. 38: Fixing the ventilation unit – flush-mount installation

### 11.7.3 U<sup>2</sup> integrated into wall installation

#### 11.7.3.1 Fitting the adapter (U<sup>2</sup> adapter kit)

- ▶ Lift up the two air flap frames (item 1 in Fig. 39) which are seated in the ventilation unit by default.
- ▶ Insert the two adapters (item 2 in Fig. 39) from the U<sup>2</sup> adapter kit into the holders (item 3 in Fig. 39) on the ventilation unit, as shown in Fig. 39.

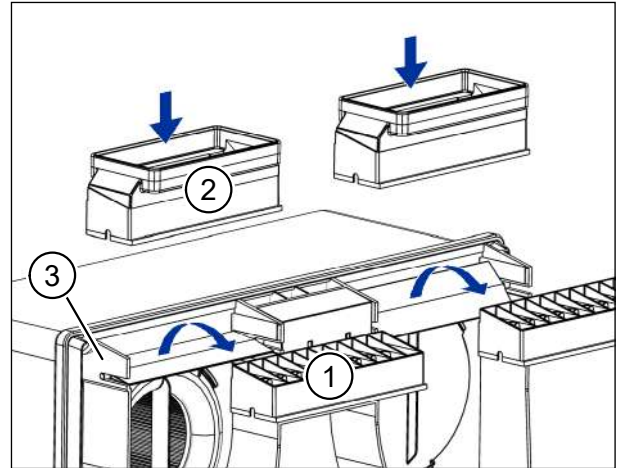

Fig. 39: Fitting the adapter (U<sup>2</sup> adapter kit)

#### 11.7.3.2 Inserting the ventilation unit into the installation kit

- ▶ Place the ventilation unit on the installation kit so that the ventilation connecting pieces on the back of the ventilation unit are lined up with the ventilation pipes of the installation kit.
- ▶ Carefully push the ventilation unit into the installation kit.

#### NOTICE

Wet the top edge of the adapter (item 1 in Fig. 40) with washing-up liquid or Vaseline so that the ventilation unit slides more easily into the installation kit.

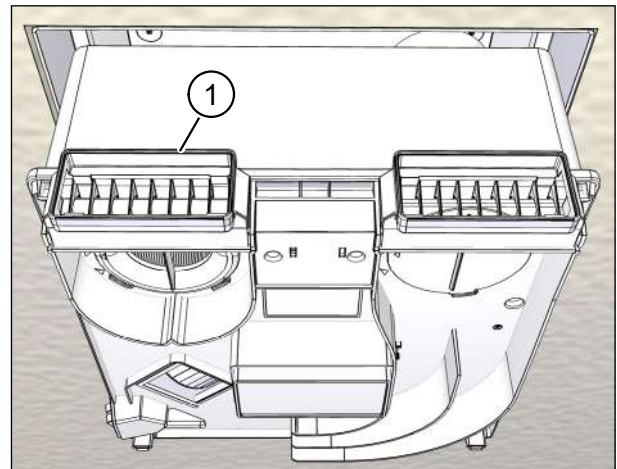

Fig. 40: Fixing the ventilation unit – U<sup>2</sup> integrated into wall installation

### 11.7.3.3 Fixing the ventilation unit

- ▶ Push the ventilation unit into the installation kit as far as it will go.
- ▶ Check that the adapters are seated correctly (item 1 in Fig. 41). They must line up with the extract air and supply air ducts of the installation kit.
- ▶ Use the four 5 x 100 mm cross-head screws (see Fig. 33 on page 34) to fix the ventilation unit to the installation kit. **Lightly** tighten the screws using a diagonal sequence.
- ▶ Tighten the cross-head screws using a diagonal sequence.

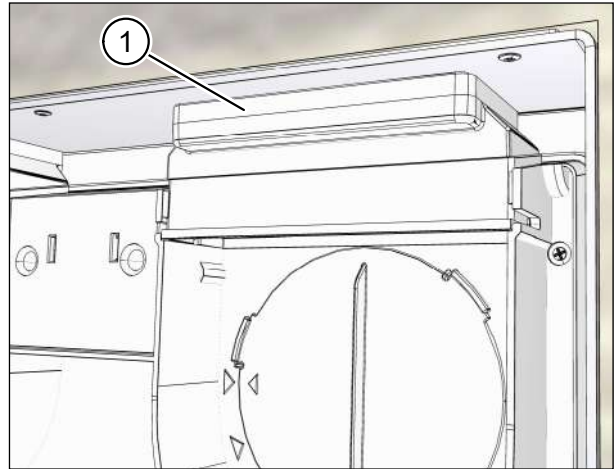

Fig. 41: Checking that the adapters are seated correctly

### 11.7.3.4 Fixing the unit cover pull-out strap to the left-hand unit cover retainer

- ▶ Take the unit cover pull-out strap (item 1 in Fig. 42) from the U<sup>2</sup> adapter kit (see section 6.2.3 on page 19).
- ▶ Remove the protective film from the glue dot on the unit cover pull-out strap.
- ▶ Stick the unit cover pull-out strap to the top of the left-hand unit cover retainer (item 2 in Fig. 42).
- ▶ Make sure that the unit cover pull-out strap is hanging down.

#### NOTICE

The unit cover pull-out strap will make it easier to lift off the unit's cover at a later date, e.g. to change the air filters.

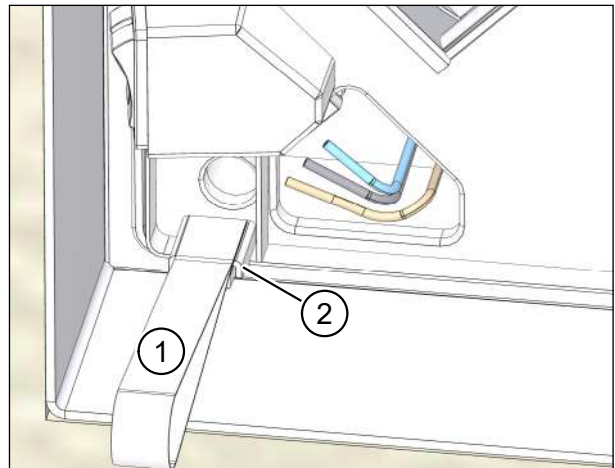

Fig. 42: Sticking on the unit cover pull-out strap

## 11.8 Connecting the mains cable and control cable (if used)

### **⚠ DANGER**

#### **Potentially fatal voltages**

- The electrical installation work must only be carried out by a qualified electrician.
- The VDE regulations or any special safety regulations applicable in your country apply to the electrical installation work.
- ▶ Before starting installation or maintenance work, disconnect the mains cable for connecting to the ventilation unit on all poles from the mains supply.
- ▶ Observe the five safety rules (DIN VDE 0105-100, EN 50110-1) for working on electrical systems:
  - Disconnect from mains (all-pole disconnection of a system from live parts)
  - Secure against reconnection
  - Check that the system is voltage-free
  - Earth and short-circuit
  - Cover or block off access to adjacent live parts

### **NOTICE**

- The ventilation unit may be damaged if the mains or control cable is connected incorrectly. This will also invalidate the warranty.
- No protective earth (PE) conductor is required.

- ▶ Connect the neutral conductor N (item N in Fig. 43) and the outer conductor L (item L in Fig. 43) to the screw terminal in the ventilation unit.
- ▶ If used, connect the wire for the external control input (item S in Fig. 43) to the screw terminal.
- ▶ Connect the control cable (if used) to the ventilation unit (only on certain ventilation units, see Table 4 on page 29).

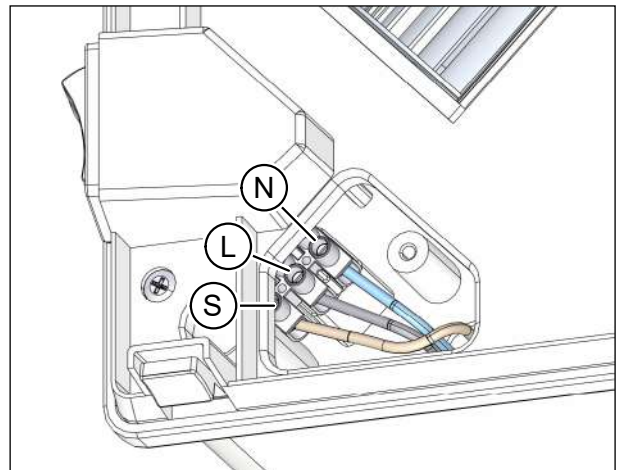

Fig. 43: Connecting the mains cable and control cable (if used)

### **NOTICE**

Connection of the control cable is described in separate installation manuals.

## 11.9 Fixing the supply air hood

### **⚠ WARNING**

**Do not run without the supply air hood.**

Please note that the ventilation unit must not be used without the supply air hood. The supply air hood is designed to prevent contact with live and rotating parts.

- ▶ Push the supply air hood (item 1 in Fig. 44) into the slotted guide (item 2 in Fig. 44). Push until you hear the latches snap into place.
- ▶ Use the screw (item 3 in Fig. 44) to fix the supply air hood.

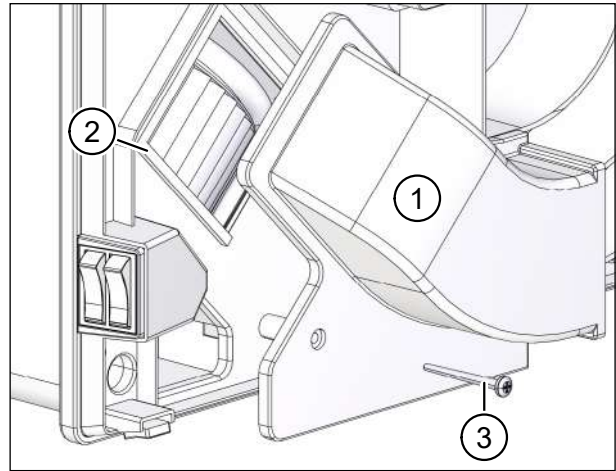

Fig. 44: Fixing the supply air hood

## 11.10 Inserting the network connection cover (on certain ventilation unit types only)

### **NOTICE**

If a control cable was connected to the ventilation unit, the network connection cover must be inserted again. You will find the affected ventilation units in Table 4 on page 29.

- ▶ Place the network connection cover (item 1 in Fig. 45) over the opening (item 2 in Fig. 45) and lock it in place.

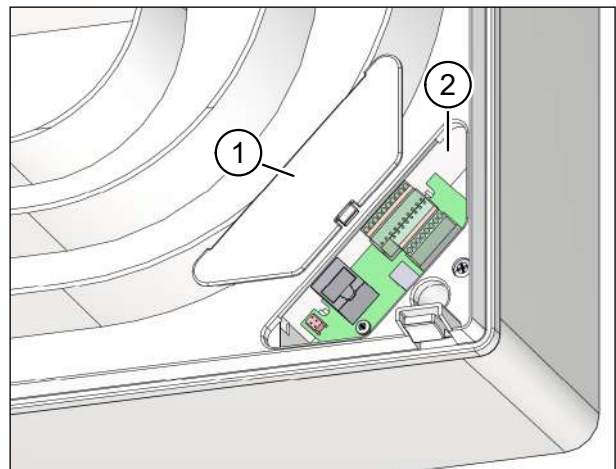

Fig. 45: Inserting the network connection cover



### 11.11 Attaching the unit cover to the ventilation unit

- ▶ Hold the ventilation unit cover with both hands and tilt the top edge of the cover towards the ventilation unit.
- ▶ Insert the tabs (item 1 in Fig. 46) of the unit cover into the openings on the top of the ventilation unit.
- ▶ Lightly press the bottom edge of the cover against the ventilation unit until you hear the cover snap in place.

#### NOTICE

For U<sup>2</sup> integrated into wall installation, make sure that the unit cover pull-out strap (item 1 in Fig. 42 on page 38) is hanging down beneath the unit cover.

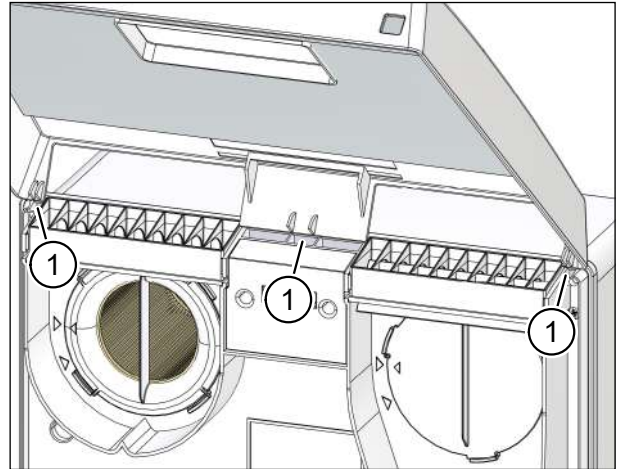

Fig. 46: Attaching the unit cover to the ventilation unit

### 11.12 Attaching the blind frame (optional for flush-mount installation without ductwork connection)

The blind frame hides unattractive gaps between the ventilation unit and the wall.

- ▶ Push the blind frame (item 1 in Fig. 47) over the installed ventilation unit until it lies against the internal wall.

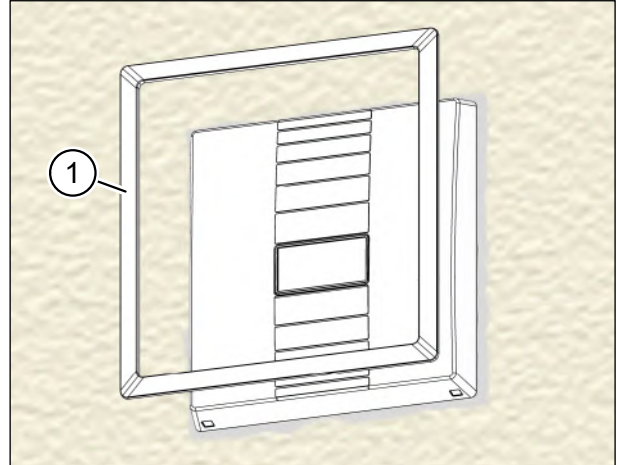

Fig. 47: Attaching the blind frame

### 11.13 Attaching the U<sup>2</sup> cover plate (for U<sup>2</sup> integrated into wall installation only)

#### NOTICE

- Remove remaining plaster and other soiling so that the U<sup>2</sup> cover plate (item 1 in Fig. 48) can lie against the internal wall without gaps.
- Wait until the paint on the internal wall is completely dry before attaching the cover plate.

- ▶ Hold the cover plate by the side edges and tilt it towards the top edge of the wall box.
- ▶ Place the top edges of the retaining plates on the back of the cover plate against the top edge of the wall box.
- ▶ Carefully lower the cover plate. The recesses on the retaining plates slide around the pins (item 2 in Fig. 48) of the wall box frame.

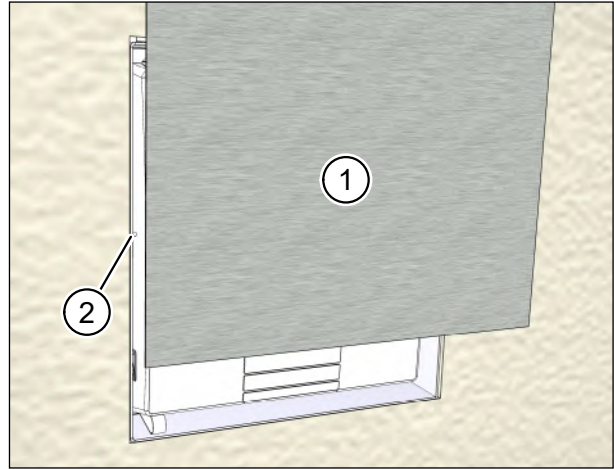

Fig. 48: Attaching the U<sup>2</sup> cover plate

#### ⚠ CAUTION

##### Risk of injury from falling cover plate

Slide the cover plate down very carefully and make sure that it is engaged securely.

### 11.14 Connecting flat ducts to the ventilation unit (for surface-mount installation with ductwork connection only)

- ▶ Remove the air flap frames (see description and Fig. 39 in section 11.7.3.1 on page 37).
- ▶ Insert the duct adapters (item 1 in Fig. 49) into the ventilation unit (see description and Fig. 39 in section 11.7.3.1 on page 37).
- ▶ Assemble the flat ducts as shown in your plans.
- ▶ Attach the unit cover to the ventilation unit (see section 11.11 on page 41).

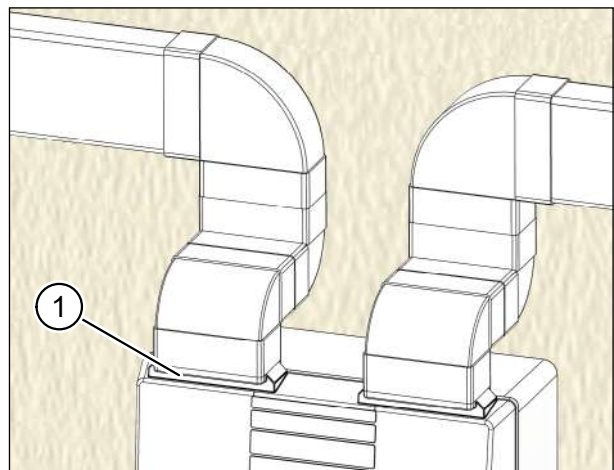

Fig. 49: Connecting flat ducts to the ventilation unit

### 11.15 Fixing the duct adapter (for flush-mount installation with ductwork connection only)

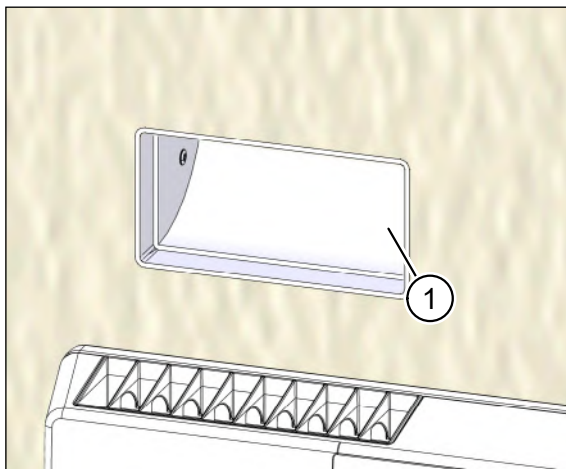

Fig. 50: Cleaning the ductwork connection

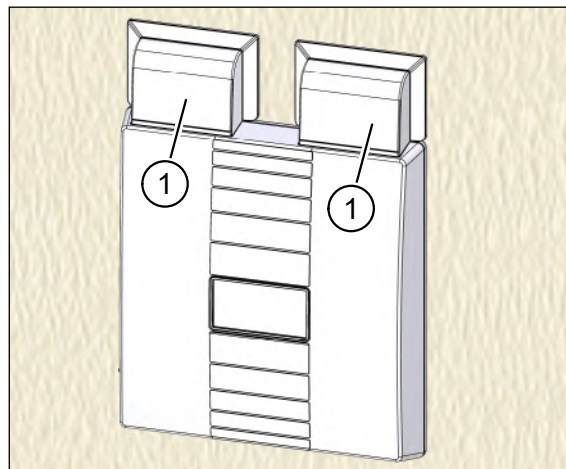

Fig. 51: Fixing the duct adapter

- ▶ Remove any soiling (e.g. remaining plaster) from the ductwork connections in the wall (item 1 in Fig. 50).
- ▶ Fix the duct adapter (item 1 in Fig. 51) as described in the relevant assembly instructions (see section “1.11 Supplementary documents” on page 8).

### 11.16 Starting up the ventilation unit

- ▶ Start up the ventilation unit as described in the instructions provided with the unit.



We have checked the content of this publication for conformity with the product described in it. There may nevertheless still be differences, so we cannot guarantee complete accuracy.

The information in this publication is regularly checked and any necessary corrections are made in subsequent editions.

Copyright © Meltem Wärmerückgewinnung GmbH & Co. KG

We reserve the right to make changes.

Meltem Wärmerückgewinnung GmbH & Co. KG  
Am Hartholz 4  
D-82239 Alling  
Germany  
Tel. +49 8141 404179-0  
Fax +49 8141 404179-9  
Internet: [www.meltem.com](http://www.meltem.com)  
Email: [info@meltem.com](mailto:info@meltem.com)



Go to  
Meltem download area